

TECHNICAL INFORMATION SHEET

Well boards for well trailers

This Technical Information Sheet outlines the requirements for well boards that are used for blocking when transporting steel coils in the well.

1. Well board design

- Well boards must be matched to the trailer well in which they are used:
 - same **well angle** to provide support to the well board when used as part of the trailer deck
 - same **well width** to ensure correct coverage and edge support
 - same **well lip depth** to ensure well-board does not cause a tripping hazard.
- Well boards should be designed to provide the same **vertical loading** capability as the trailer bed (able to withstand forklift axle load of 5.46 tonnes).
- Well boards should be capable of withstanding **horizontal loading** of 10 tonnes in compression.
- Well boards can be manufactured in various ways to provide sufficient strength, for example:

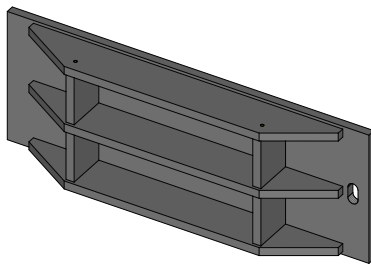
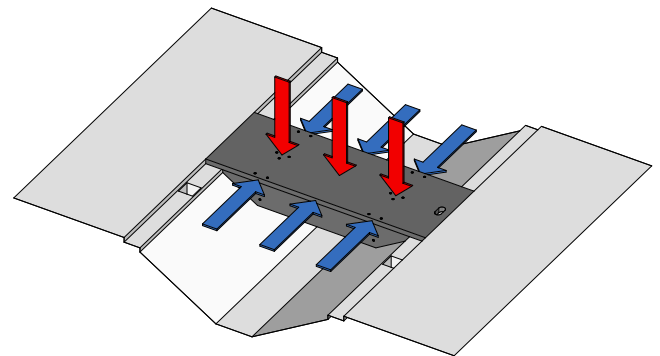

- ✓ Plywood frame. Minimum thickness 25mm first grade ply.

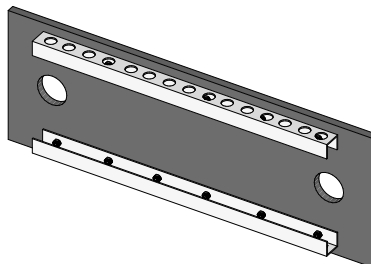

- ✓ Longitudinal steel members - no cross bracing. Minimum thickness 25mm first grade ply.

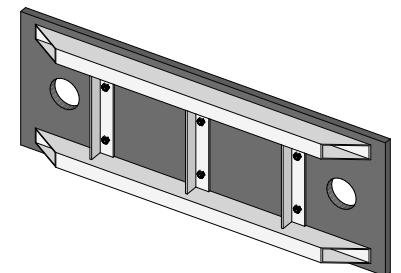

- ✓ Steel frame with cross bracing. Minimum thickness 20mm first grade ply.

2. Well board condition

Key areas to inspect include:

- Frame condition and joints
 - check for cracks / splits / gaps.
- Fixing of decking surface to frame
 - check for missing or loose screws / bolts.
- Condition of decking surface
 - check for warping and de-lamination.
- Edges must not be chamfered or worn.
- Well boards must fit square and flat in the well.

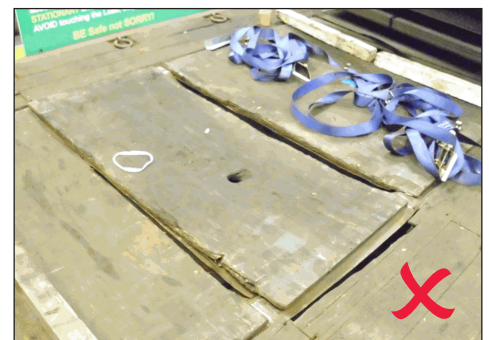

TECHNICAL INFORMATION SHEET

Well boards for well trailers

3. Use of well boards for blocking

3.1 Against well posts

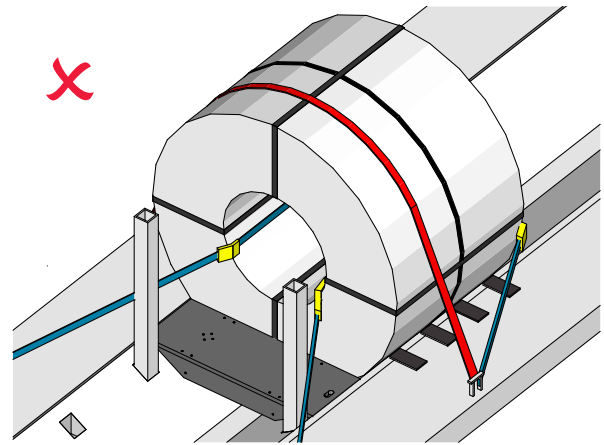
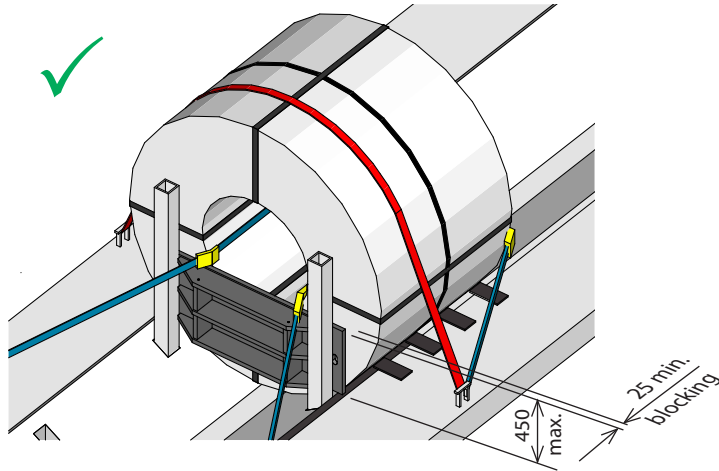

- ✓ Well board fits flush between posts and coil.
- ✓ Well board cannot slide out sideways.
- ✓ Maximum well board height 450mm to keep bending force low down on the posts.
- ✓ Minimum blocking thickness 25mm when used in this orientation to ensure coil does not topple against upper part of posts.

- ✗ Do not use a well board horizontally as spacing between the coil and **well posts**. The well board edges will crush due to concentrated point loading under heavy braking.
- If spacing is needed between well posts and coil to achieve axle loadings, then use minimum 100mm square timbers as blocking.

3.2 Multiple coils

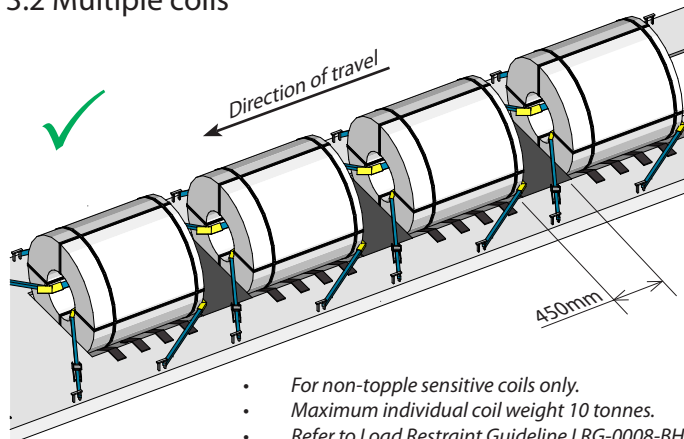

- For non-topple sensitive coils only.
- Maximum individual coil weight 10 tonnes.
- Refer to Load Restraint Guideline LRG-0008-BH for Wide coil in well.

- When used as blocking between coils, the well boards must have clean square edges to ensure that they do not flip out under load.
- Well boards must have a minimum decking thickness of 20mm to ensure adequate spread of load across the coil faces.

- ✓ 450mm wide well boards will provide sufficient access for crane tongs in the majority of cases.
- If additional spacing is required between coils wider **higher strength** boards should be used:
 - minimum of 25mm thick first grade ply.
 - secured to frame with cross members.
 - recommended maximum width of a single well board is 600mm.
- ✓ Front coil must be placed against front of well or against well posts to provide load restraint in forward direction - **relying on a well board against the front lip of the well is not sufficient.**
- ✓ Maximum of **one** well board between coils to avoid flipping out under load.

Well boards are an integral part of the restraint systems shown above and must be inspected regularly.

Care has been taken to ensure that the contents of this publication are accurate, but Tata Steel Europe Limited and its subsidiaries do not accept responsibility or liability for errors or information that is found to be misleading.