

TECHNICAL INFORMATION SHEET

Load restraint incident checklist

This Technical Information Sheet is to be used as a checklist to ensure all necessary information is recorded following any load shift / load loss incidents so that a full analysis of the restraint system can be conducted.

✓ Take as many photographs as possible.

✓ Keep all damaged restraints for inspection.

Stage 1 Immediate action

✓ when complete

1. Notify Managing Contractor (*XPO, P&O*) or the Tata Steel contract owner immediately

Identify any personal injuries to the driver or others.

2. Record details of the incident:

Location

Time

Conditions (*weather, traffic volume, lighting/visibility, road condition etc.*)

Product (*type, weight, size, surface treatment, packaging etc.*)

Pick-up location (*Tata Steel site*)

Customer (*company name and location*)

What happened to cause the incident (*speed, evasive manoeuvre etc.*)

Outcome of the incident (*load shift, load shed*)

Driver name, haulage company name, vehicle registration, trailer number

3. Identify and record:

Any damage to vehicles (*tractor unit, trailer and others involved*)

Any damage to product

DO NOT DELIVER WITHOUT PERMISSION FROM MANAGING CONTRACTOR OR CONTRACT OWNER

The information and guidance contained in this document is intended for use only by Tata Steel UK Limited and its associated and subsidiary companies ("Tata Steel") in relation to its operations. All information and guidance in this document is based on Tata Steel's interpretation of prevailing legislation and best practice. Tata Steel gives no warranty or representation as to the accuracy of the information or for the guidance being for, or suitable for, a specific purpose. The information and guidance does not constitute legal or professional advice. All implied warranties and conditions are excluded, to the maximum extent permitted by law. Use of this document by any third party is at your own risk. Save to the extent that liability cannot be excluded by law, Tata Steel is in no way responsible or liable for any damage or loss whatsoever arising from the use of or reliance on the information and guidance contained in this document.

TECHNICAL INFORMATION SHEET

Load restraint incident checklist

Stage 2 Collect evidence to help the incident investigation

4. Sketch of load prior to incident

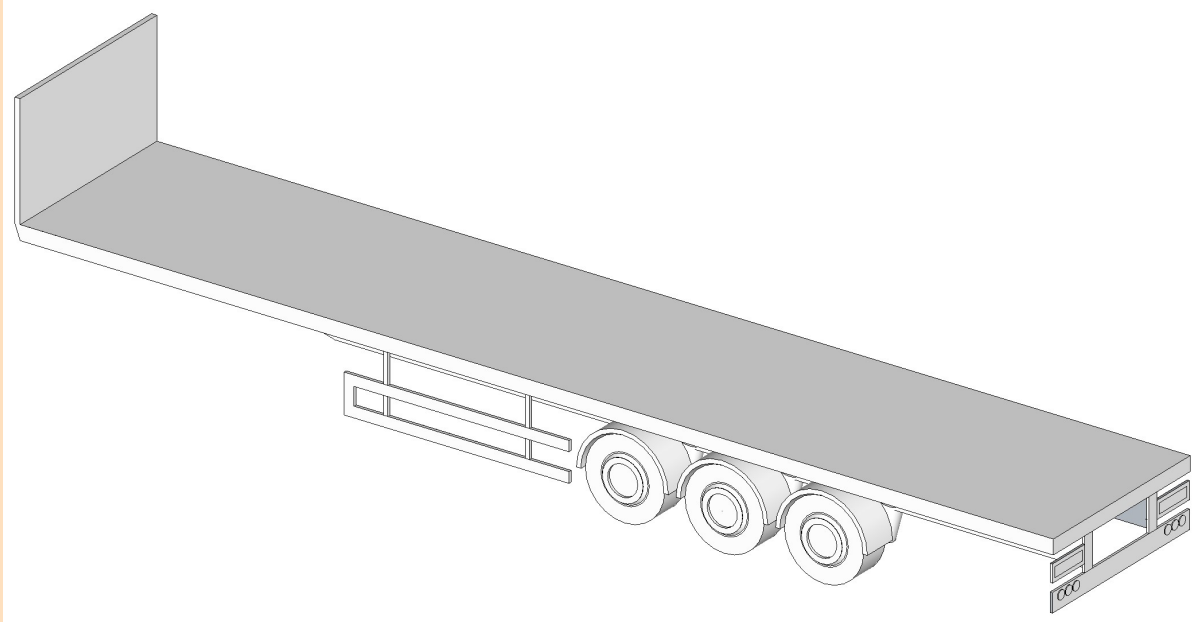

5. Identify and record details of the load restraint system:

✓ when complete

Trailer type and specification (e.g. XL curtainsider, flatbed, well trailer etc.)

Lashing point connection (e.g. rated lashing point, side rave, chassis beam etc.)

Distance of product from headboard before incident

Any vertical gaps in the load before the incident (controlled / uncontrolled)

Size and condition of all timber dunnage (base, intermediate and vertical)

Size and condition of any blocking used (timbers, false headboards, cross-over restraints etc.)

Size and condition of side posts and stanchions (height, cross-section e.g. 80 x 80 mm x 4 thick)

Type of restraints and tensioners used (straps, chains, ratchets, bottle tensioner etc.)

Number and position of restraints and tensioners

Restraint method (over-the-top, belly-wrapping, cross-over etc. and LRG ref. if applicable)

Use of edge protection

Use of anti-slip matting

6. Photographs - take as many photographs as possible covering:

The general scene of the incident

The position of the load after the incident

The condition of the restraints (straps, chains, blocking, dunnage, posts etc.)

Condition of the trailer after the incident

Indication of where the load was positioned on the trailer before the incident