

TECHNICAL INFORMATION SHEET

Timber dunnage

1. General purpose dunnage

- ✓ 1st Grade softwood or better - no bark.
- ✓ Square cross-section - see Table 1 below for minimum allowable sizes.

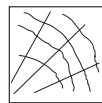

- ✗ Do not use timbers with damaged or crushed corners that will cause the timber to roll - 15% rule e.g. 15 mm damage on a 100 mm square timber is the limit of allowable corner damage.



- ✓ Base dunnage must span full width of trailer for billet, bloom, section, bar, rail, tube etc.

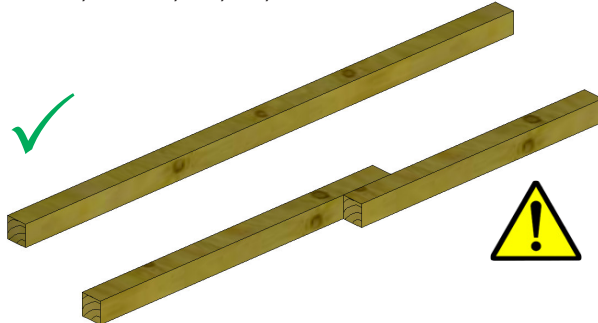

- Overlapping not recommended except in plate loads.
 - Potential for inadequate overlap leading to product dropping through the gap.
 - Provides poor clamping through the load.

Table 1: Minimum timber sizes

Purpose	Minimum size (mm)	Weight @ 2.4m *
Base dunnage for 50 t forklift tines (std)	150 x 150	27 kg
Base dunnage for 50 t forklift tines (thin)	125 x 125	19 kg
Intermediate dunnage spanning large gaps in the load	100 x 100	12 kg
General purpose dunnage	75 x 75	7 kg
Packing timbers - not full width	60 x 60	n/a
Separating plates (Placed at an angle to prevent rolling)	50 x 50	n/a

* Based on softwood with 12% moisture content (add 30% for hardwood)

Double stacked dunnage / rectangular timbers

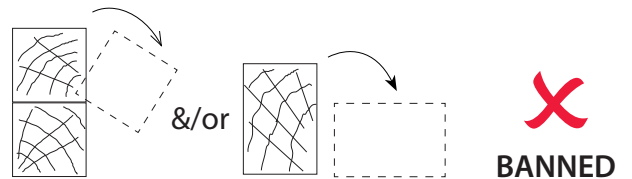

- Under heavy braking double stacked dunnage and rectangular timbers on end will topple allowing the load to fall; thereby releasing tension in the restraints.

1-on-2 stacking

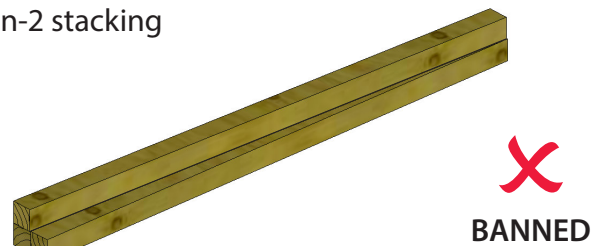

- Similar to double stacked dunnage; top timber will still slide off under heavy / emergency braking.

Grillage

- To raise dunnage, place centrally on shorter bearers. The shorter bearers must be long enough to prevent the main timber from sliding off under emergency braking. Minimum length of short bearers 600 mm. Sufficient short lengths must be placed to support the main timber adequately.

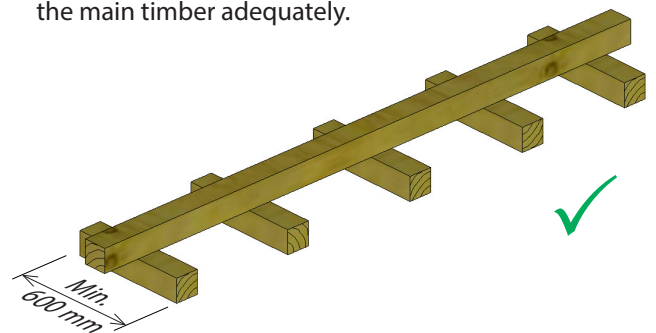

Damaged timbers

- Cracked or worn timbers must be replaced.

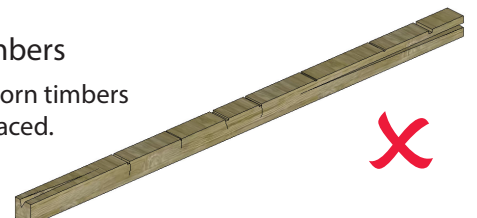

TECHNICAL INFORMATION SHEET

Timber dunnage

2. Intermediate dunnage

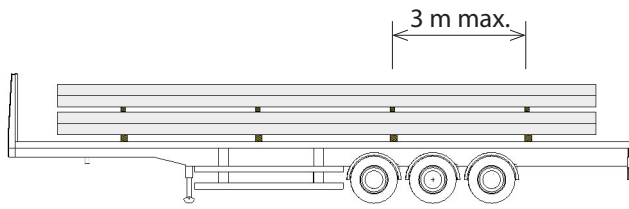

- Where loading practices allow it, intermediate dunnage should be vertically aligned with the base dunnage.
- 3 m is the **maximum** span between intermediate timbers to prevent product distortion / timber failure.
 - *Note: Some loads will require more timbers e.g. thin plate may require 8 timbers to support a 12 m load.*
- When there is a mismatch in stack/bundle heights in a load, packing timbers will be required to ensure the intermediate dunnage is horizontal - options are shown below:

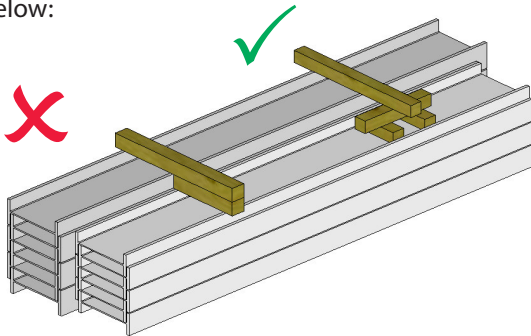

Do not double stack timbers in line, and do not balance timbers on the flanges of beams - create a stable grillage to fill the void.

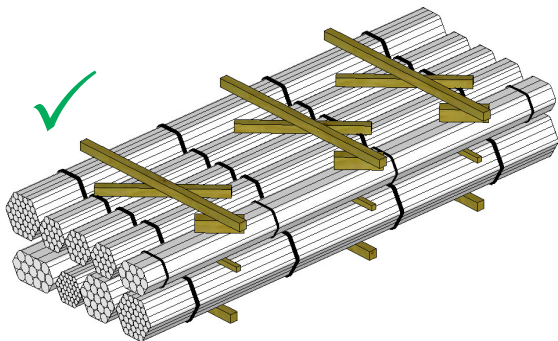

Place packing pieces at an angle to prevent upper timbers sliding off.

- When spanning large gaps, such as universal beams, use 100 x 100 mm minimum intermediate timbers.

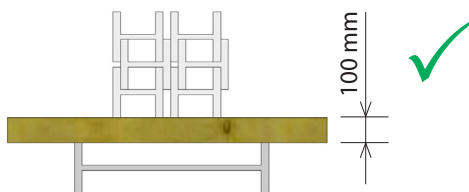

- Product should not be placed on overhanging timbers:

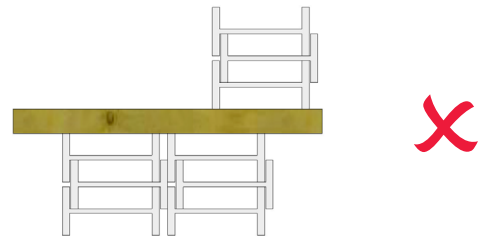

- Intermediate dunnage must span the full width of the product below it:

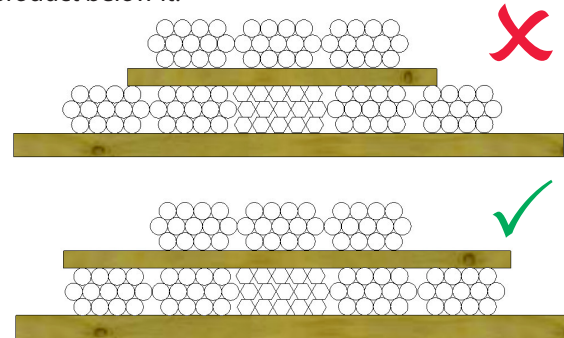

3. Vertical dunnage

- Where chain gaps are required for loading/unloading, vertical dunnage must be used to control these gaps. See *Technical Information Sheet TIS-0007*.

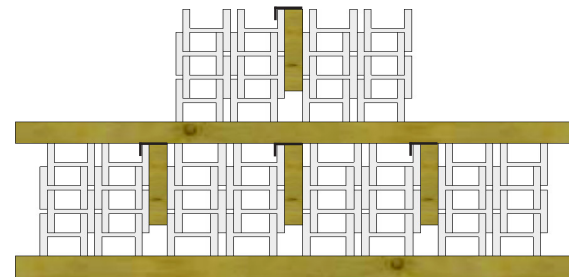

4. Triangular dunnage

- Triangular dunnage is commonly used with round products to prevent rolling during loading/unloading.

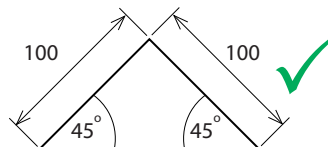

- Recommended 100 x 100 mm min.
- Placed on long edge.

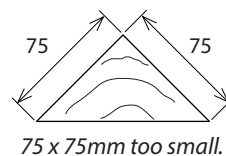

75 x 75mm too small.

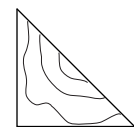

Unstable on its short edge.

The information and guidance contained in this document is intended for use only by Tata Steel UK Limited and its associated and subsidiary companies ("Tata Steel") in relation to its operations. All information and guidance in this document is based on Tata Steel's interpretation of prevailing legislation and best practice. Tata Steel gives no warranty or representation as to the accuracy of the information or for the guidance being for, or suitable for, a specific purpose. The information and guidance does not constitute legal or professional advice. All implied warranties and conditions are excluded, to the maximum extent permitted by law. Use of this document by any third party is at your own risk. Save to the extent that liability cannot be excluded by law, Tata Steel is in no way responsible or liable for any damage or loss whatsoever arising from the use of or reliance on the information and guidance contained in this document.