

# LOAD RESTRAINT GUIDELINE

## Slit coil bore vertical - Colorsteels

### 1. This guideline applies to:

- Slit coils bore vertical banded to pallets and loaded in single layer.
- Product finish: galvanised and cold rolled.
- Packaging: bare coils, VCI wrapped and film wrapped.

Note: The lowest friction factor as defined in EN 12195-1:2010 Annex B.2 is  $\mu=0.45$

### 2. Essential requirements

- All restraints must be webbing straps compliant with EN 12195-2, minimum lashing capacity of 2000 daN.
- Edge protection must be used on all sharp edges including trailer side raves.
- Slit coils must be securely banded to the pallets (see Section 7).
- Maximum 3 tonnes per pallet.
- Maximum 3 tonnes per pair of pallets stacked side by side.
- Maximum 7.5 tonnes per group of coils behind each **direct lashing**.

### 3. Restraint system overview

- ✓ Pair of **cross-over** straps applied to each stack.
- ✓ **Direct strap** applied to each group of coils.

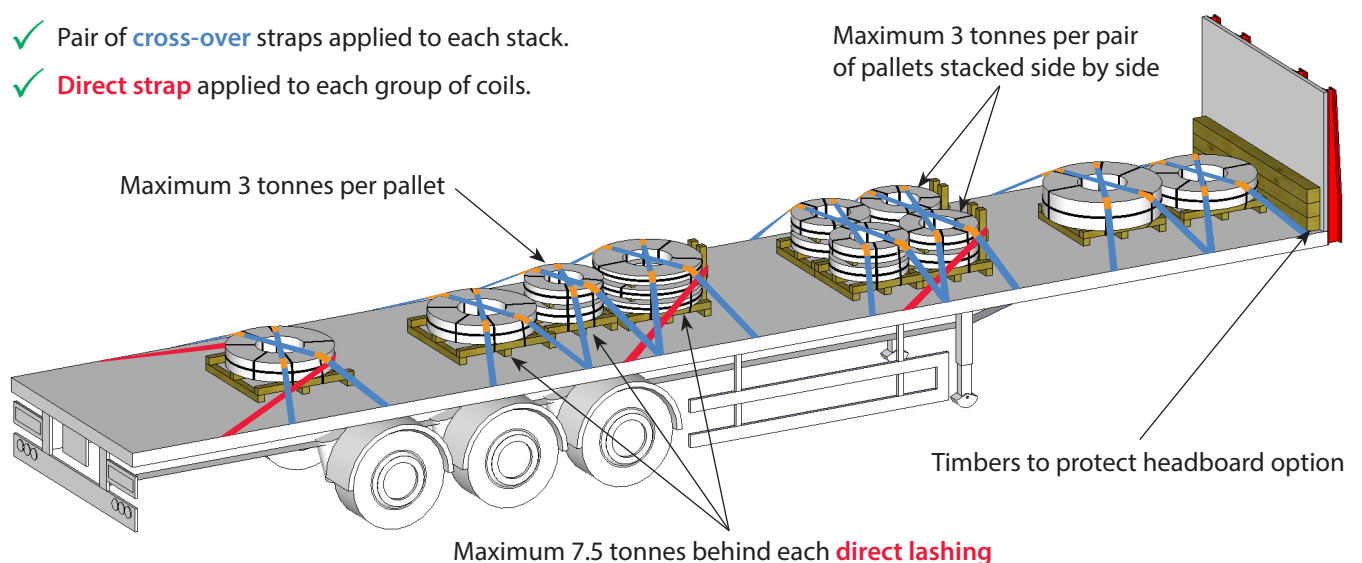

This Load Restraint Guideline has been designed and tested to meet the forces for road and sea transport as stated in EN 12195-1:2010 and VDI 2700.

# LOAD RESTRAINT GUIDELINE

## Slit coil bore vertical - Colorsteels

### 4. Forward restraint options

#### 4.1 Restraint with direct lashing

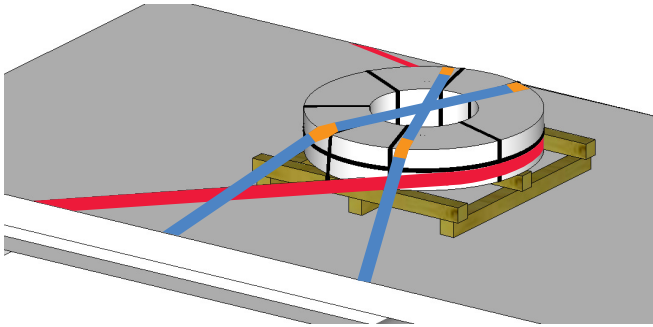

- ✓ Pallet can be utilized to prevent **direct lashing** from sliding down.

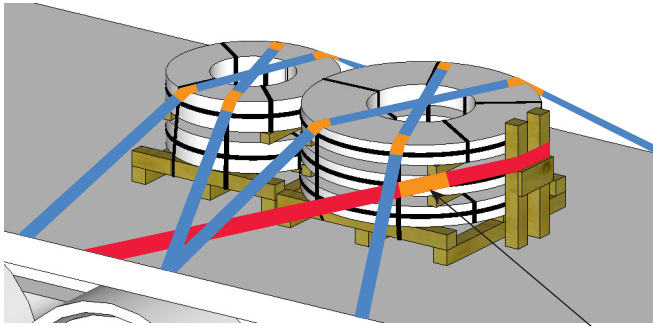

- ✓ Wooden frames or T-blocks must cover full height of the stack and prevent strap from sliding down.
- ✓ Use edge protection or additional wooden frame to prevent contact between straps and sharp edges of the coil.
- ✓ Maximum 7.5 tonnes behind each **direct lashing**.

Edge protection applied to strap in contact with edge of the coil

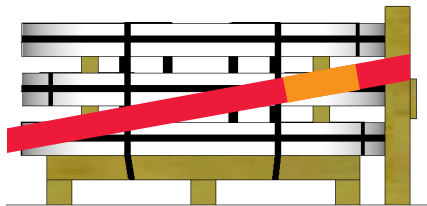

- ✓ When using H-frame or T-block position **direct lashing** close to the centre of the coil or stack of coils.

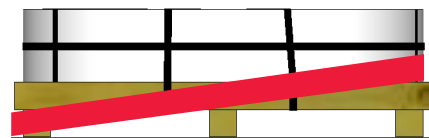

- ✓ When applying **direct lashing** directly to a single coil ensure that pallet prevents lashing from sliding down.

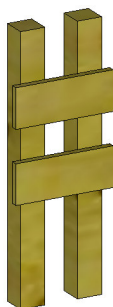

*Example of H frame.*

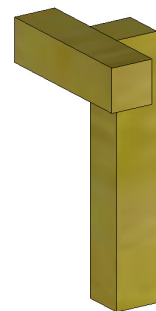

*Example of T block.*

# LOAD RESTRAINT GUIDELINE

## Slit coil bore vertical - Colorsteels

### 4.2 Blocked against the headboard

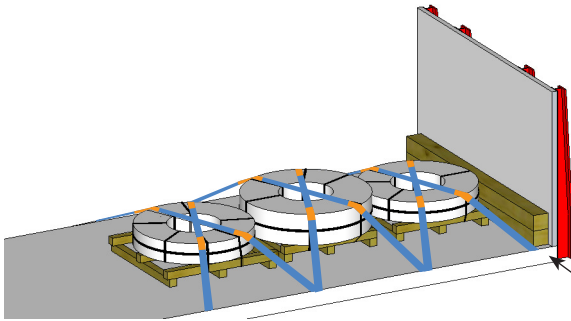

Headboard capacity	Maximum weight loaded against the headboard
10 tonnes	Full payload
5 tonnes	12 tonnes

Timbers to protect headboard (optional)



**Note:**

Timbers may be stacked and secured between the product and the headboard in order to prevent damage to the headboard e.g. headboard without steel plate.  
Strap timbers down if using a flatbed trailer with no covers.

### 5. Stack dimension requirements

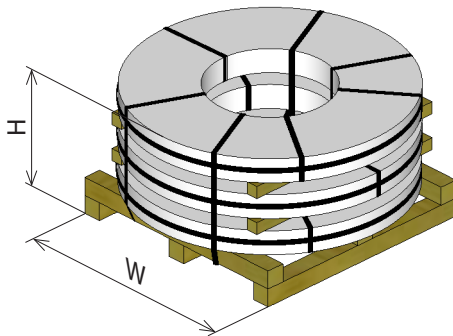

✓ Total height (H) must be less than pallet width (W).

### 6. Headboard requirements

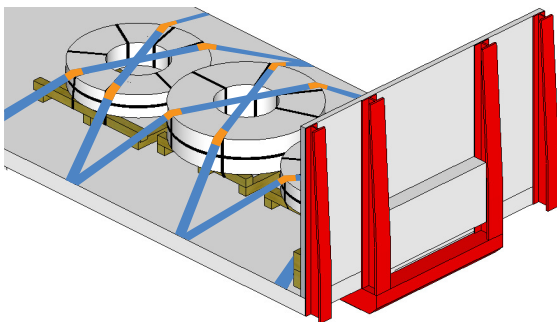

When trailer headboards are used as part of the load restraint system they must be capable of providing adequate blocking force. For more information refer to Technical Information Sheet TIS-0010 Trailer Headboards.

Trailers with headboards rated to EN 12642 code XL will provide up to 13.5 tonnes of blocking force and will therefore, be suitable for blocking a full load of slit coil bore vertical.

Fahrzeugaufbau entspricht	<b>EN 12642-XL</b>
Voertuigopbouw voldoet aan norm	
Vehicle body in compliance with	
LAG TRAILERS N.V.	2008

Typical plaque on a trailer manufactured to EN 12642 code XL.

# LOAD RESTRAINT GUIDELINE

## Slit coil bore vertical - Colorsteels

### 7. Banding requirements

Tables below show the number of packaging bands (steel or plastic) required to secure slit coil(s) to the pallet.

**Table 1: Minimum number of bands - UK loads**

Weight of pallet	Minimum number of bands
up to 1 tonne	2
up to 2 tonnes	3
up to 3 tonnes	4

**Table 2: Minimum number of bands - export loads**

Weight of pallet	Minimum number of bands
up to 1 tonne	2
up to 2 tonnes	4
up to 3 tonnes	5



### 8. Export loads

- ✓ Anti slip-matting positioned between pallets and trailer deck.
- ✓ Each group of coils secured against rearward movement by **direct lashing** pulling forward.

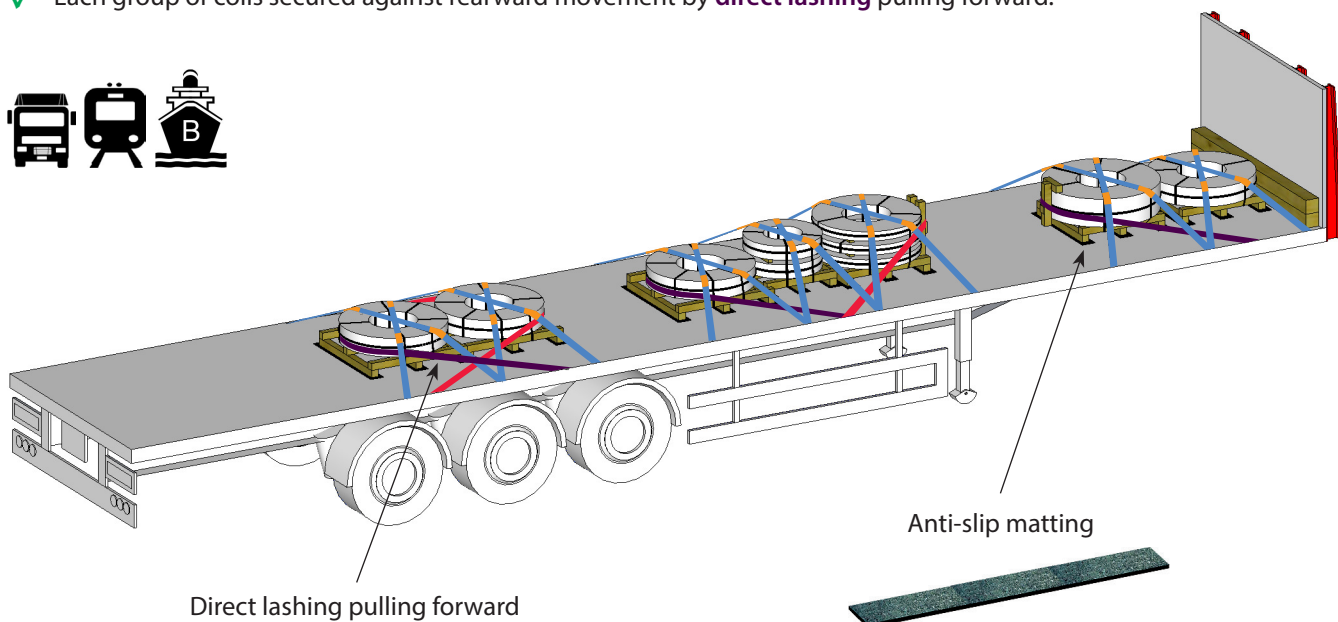

### 9. Winter weather UK and export loads

During severe winter weather advisory periods when the air temperature is below 0°C and there is a risk of frost, ice or snow anti slip-matting must be positioned between pallets and trailer deck.

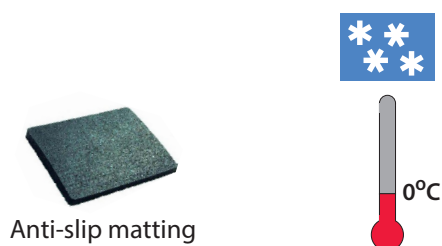

The information and guidance contained in this document is intended for use only by Tata Steel UK Limited and its associated and subsidiary companies ("Tata Steel") in relation to its operations. All information and guidance in this document is based on Tata Steel's interpretation of prevailing legislation and best practice. Tata Steel gives no warranty or representation as to the accuracy of the information or for the guidance being for, or suitable for, a specific purpose. The information and guidance does not constitute legal or professional advice. All implied warranties and conditions are excluded, to the maximum extent permitted by law. Use of this document by any third party is at your own risk. Save to the extent that liability cannot be excluded by law, Tata Steel is in no way responsible or liable for any damage or loss whatsoever arising from the use of or reliance on the information and guidance contained in this document.