

LOAD RESTRAINT GUIDELINE

Reversing mill plate using webbing straps

1. This guideline applies to:

- Individual plates or multiple plates banded together. Excludes sheet packs.
- Mill finish, heat treated, profiled, shotblast, and shotblast & primed plate.

For this combination of plate finishes, the lowest friction factor determined as per EN 12195-1:2010 Annex B.1.2 is $\mu = 0.47$.

2. Essential requirements

- All restraints must be webbing straps compliant with EN 12195:2001-2.
- Webbing straps must be protected from abrasive surfaces and sharp edges. This includes the product, as well as the trailer chassis and side rails. Recommended types are heavy duty webbing sleeves and moulded plastic corners.
- Loads must be placed on a single layer of timber dunnage with square cross-section, minimum of 100 x 100 mm. Special dispensation is required for other types of dunnage.
- Restraint system adopted must be fully compliant with Section 3 or Section 4.
- Anti-slip matting may be introduced between all surfaces for added security or to satisfy local enforcement.

3. Overview of tie-down restraint system

All illustrations in this guideline are for LC 2000 daN webbing straps.

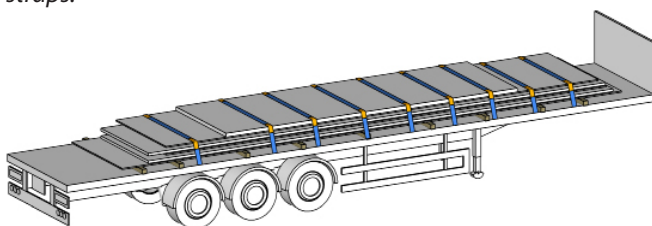

Full load of plate restrained according to requirements as stated in Table 1.

Detail on the tie-down restraint system continues on Page 2.

See Section 4 for direct restraint system.

Table 1: Minimum number of restraints

Load	LC 2000 daN	LC 2500 daN
up to 20 t	7	5
up to 28 t	9	7
Narrow load < 1800 mm	Add 1 restraint	
Wide plate > 3000 mm	Add 1 restraint	
Narrow on wide	See Section 3.2	

Note: Additional restraint is required during Severe Winter Weather advisory periods.

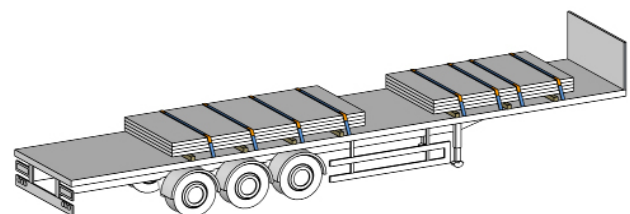

When multiple short stacks of plate are loaded onto the trailer, each stack is to be restrained with a minimum of 4 straps.

This Load Restraint Guideline has been designed and tested to meet the forces for road transport as stated in EN 12195-1:2010 and VDI 2700.

LOAD RESTRAINT GUIDELINE

Reversing mill plate using webbing straps

3.1 Tie-down restraint system

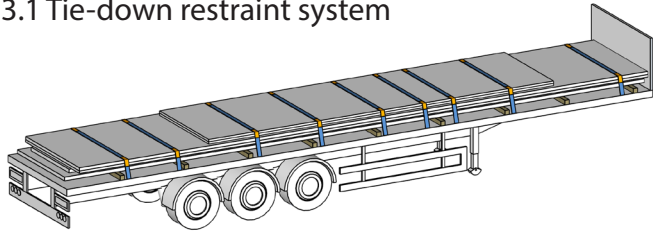

Limit of 20 tonnes on long plates loaded to the headboard. Restraints are to be concentrated over the short plates, which are loaded away from the headboard.

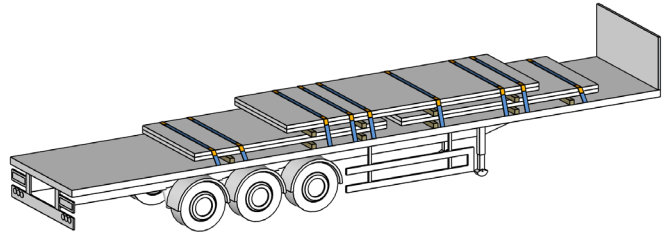

If plates bridge multiple stacks of plates, the restraints are to be distributed evenly, ensuring there are at least 4 restraints over every plate.

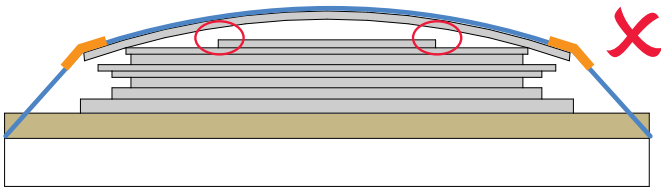

If a wide plate bows to the extent that it bridges narrow plates or intermediate timbers after the restraints have been applied, then the load must be reconfigured.

3.2 Narrow on wide

This section applies to the tie-down restraint system when the top plate or top part of the load is narrower than the plates on which they are loaded. When narrow plates are loaded directly onto wide plate, the lashing angle can approach zero. In an emergency braking situation, the narrow plate(s) could slide from under the restraints.

The narrow plate(s) must be timbered up and restraints are to be applied as stated previously.

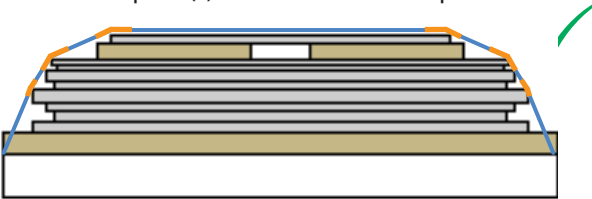

Narrow, top plate is timbered up to improve lashing angle.

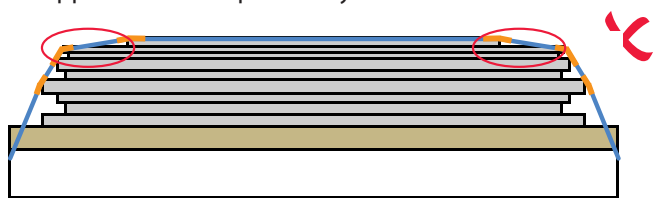

Negligible lashing angle on narrow, top plate.

If the **difference in width is 300 mm or greater**, then one of the following three options must be adopted:

Option 1

- Load narrow plates onto timbers.
- Replace front and rear tie-down restraints over the narrow plates with belly-wraps.
- Add 1 tie-down restraint.

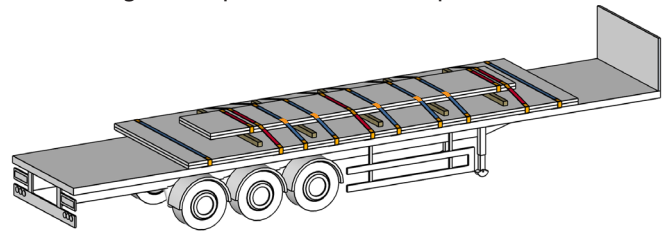

Option 2

- Load narrow plates onto timbers.
- Apply cross-over restraints around the front of the narrow plates.

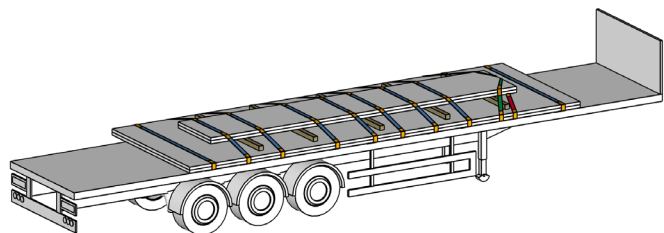

Option 3

- Each narrow plate must be placed on timbers or anti-slip matting.
- Add 1 tie-down restraint.

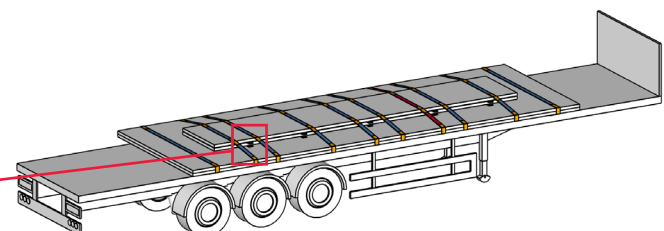
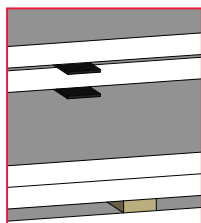

LOAD RESTRAINT GUIDELINE

Reversing mill plate using webbing straps

4. Direct restraint system

- Product to receive direct restraint in the form of blocking or cross-over restraints. See Section 5 for details on headboard, stanchion and cross-over restraint requirements.
- **Minimum of 6 tie-down restraints for a full load.**

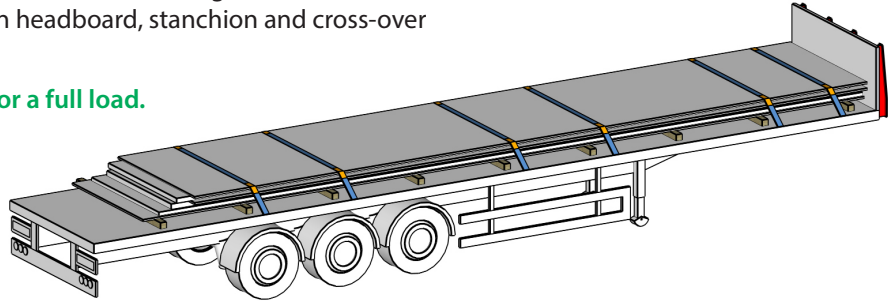

Short plates on top are loaded back from the headboard to achieve suitable axle loadings and have direct restraint in the form of cross-over restraints.

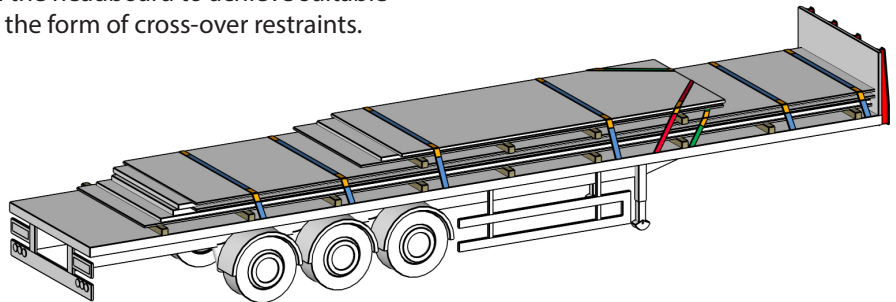

First stack receives direct restraint from stanchions, headboard or cross-over restraints.

Subsequent stacks are loaded tight against front stack.

Minimum of 3 tie-down restraints per stack.

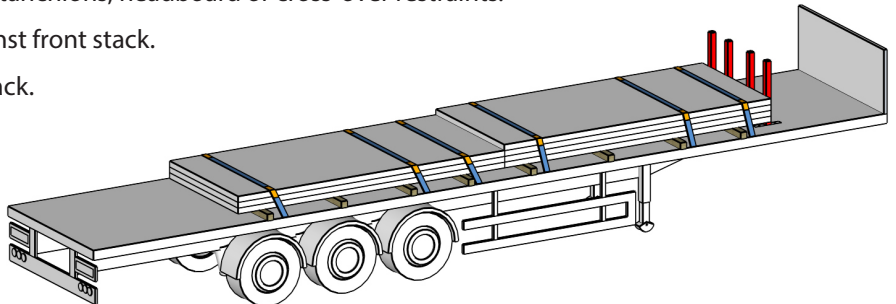

First stack is loaded to headboard. Second stack is loaded to the rear to achieve suitable axle loadings. Cross-over restraints are applied around front of rear stack for direct restraint.

Minimum of 3 tie-down restraints per stack.

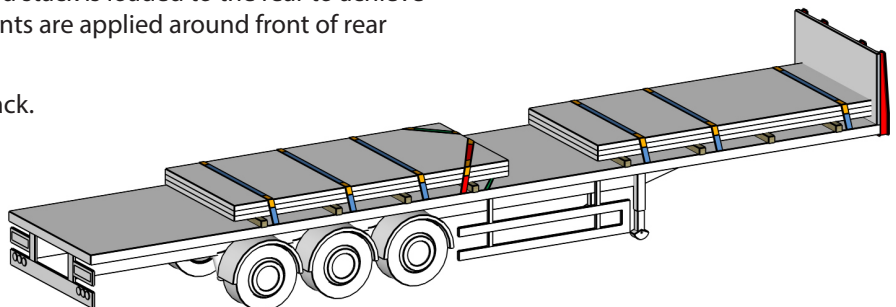

Loading requirements

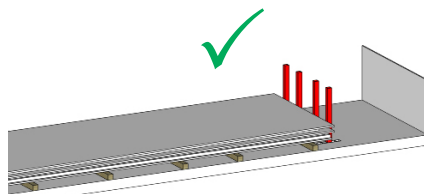

Individual short plates may be loaded away from the headboard or stanchions, provided they are in the middle of the load.

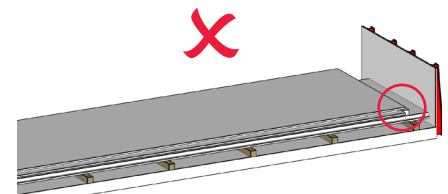

Incorrect loading. Product must be up to headboard / stanchions, or captured by cross-over restraints.

LOAD RESTRAINT GUIDELINE

Reversing mill plate using webbing straps

5. Specification of direct restraint

5.1 Headboard

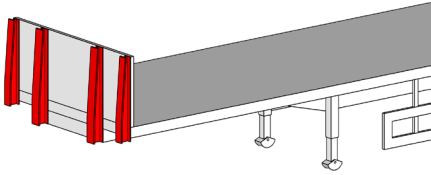

If using anti-slip matting, headboards must be capable of providing 5 tonnes of restraint. This is achieved from any of the following:

- EN 12642 Code L minimum.
- Consisting of 4 vertical supports each with 2 weld runs of 90 mm.
- Consisting of 2 vertical supports each with 2 weld runs of 130 mm.

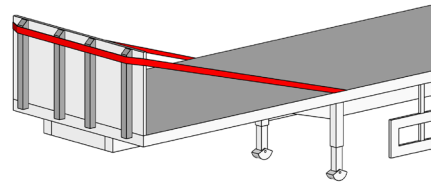

Without anti-slip matting, headboards must be capable of providing 10 tonnes of restraint. This is achieved from any of the following:

- Meet criteria above and be lashed back on both sides.
- EN 12642 Code XL.
- Consisting of 4 vertical supports each with 2 weld runs of 130 mm.

5.2 Stanchions

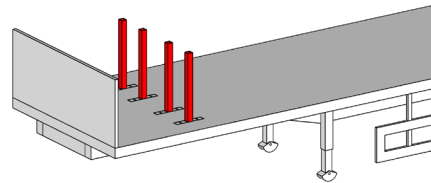

If using anti-slip matting, minimum of 2 stanchions required.

Without anti-slip matting, minimum of 4 stanchions required.

- Minimum cross-section of 80 x 80 x 4 mm.
- If cross-section is less, a greater number of stanchions is required or additional restraints must be applied.

5.3 Cross-over restraints

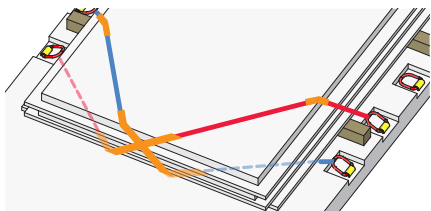

A pair of cross-over restraints may be used for a full load when using anti-slip matting, or for up to 13 tonnes without anti-slip matting.

- Webbing strap protection is critical.
- Entire portion of the strap around the front of the plates must be protected.
- Rating of lashing points must be a minimum of 2 tonnes.

6. Placement of restraints

Restraints are to be placed a minimum of 300 mm from the ends of the product.

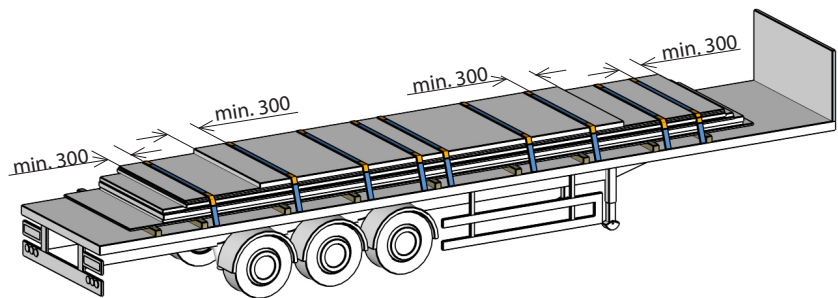

Restraints are to be placed close to dunnage to minimise product distortion. Every effort should be made to align dunnage vertically in the load.

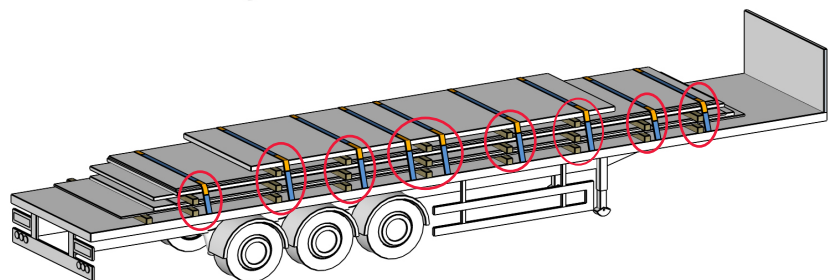

The information and guidance contained in this document is intended for use only by Tata Steel UK Limited and its associated and subsidiary companies ("Tata Steel") in relation to its operations. All information and guidance in this document is based on Tata Steel's interpretation of prevailing legislation and best practice. Tata Steel gives no warranty or representation as to the accuracy of the information or for the guidance being for, or suitable for, a specific purpose. The information and guidance does not constitute legal or professional advice. All implied warranties and conditions are excluded, to the maximum extent permitted by law. Use of this document by any third party is at your own risk. Save to the extent that liability cannot be excluded by law, Tata Steel is in no way responsible or liable for any damage or loss whatsoever arising from the use of or reliance on the information and guidance contained in this document.